

SS-35L EX

EXPLOSION PROOF / DUST IGNITION PROOF VACUUM
CLEANER SYSTEMS
PNEUMATICALLY (AIR) OPERATED
ULTIMATE EXTREME CLEANING FILTER CARTRIDGE (PTFE)
BY REVERSE PURGE
MODEL SS-35L EX (MRP) RE HEPA

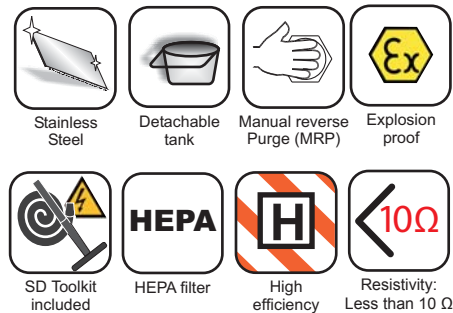

Characteristics:



CE 0081 Ex II 2 G/D EEx c IIC T6 (85°C)
LCIE 03 ATEX 6310

- All Stainless Steel AISI 304 construction (except cart).
- For dry recovery only.
- This unit is designed for applications where finely pulverized dust is to be recovered.
- Optional conductive polyliners and depressor kit are available for the safe disposal of recovered material.
- Detachable recovery tank with a capacity of 8.75 gallons (35 litres) for easy emptying of recovered materials.
- Filter cartridge made of conductive spun bond polyester with PTFE membrane.
- HEPA Filter efficiency of 99.995% @ 0.3 micron. Tested: IEST RP-CC001.3. Type H14
- Manual Reverse Purge (MRP): Filter cartridge made of conductive spun bond polyester with PTFE membrane (surface area: 40ft²/37 200 cm²).
- Cleanroom version available.
- This vacuum cleaner system, along with its accessories, is grounded to ensure static dissipation and conductivity during use. **The entire unit has a resistivity of less than 10 ohms (see reverse for details)**

Tiger-Vac[®]
...The name to vacuum with

Tiger-Vac Inc. (USA)
73 S.W. 12 Ave. Bldg.1, Unit 7
Dania, FL 33004
USA
Tel.: (954) 925-3625
Fax.: (954) 925-3626
E-mail: sales@tiger-vac.com

Tiger-Vac International Inc.
2020 Dagenais Blvd. West
Laval, Quebec
Canada H7L 5W2
Tel.: (450) 622-0100
Fax.: (450) 625-3388
E-mail: support@tiger-vac.com

Toll free telephone: 1 800 668-4437 (Fax: 1 800 668-4439)
<http://www.tiger-vac.com>

Performance chart

Compressor size	Airjet	Air line size	Input Air pressure/bar	Suction intake Ø	Vacuum H ₂ O	Airflow
30 hp	6mm	0.5" (12.7mm)	80PSI/5.5	1.5" (38mm)	170" H ₂ O (4320mm H ₂ O)	110CFM/ 52 l/s
30 hp	6mm	0.5" (12.7mm)	100PSI/6.9	1.5" (38mm)	200" H ₂ O (5080mm H ₂ O)	95CFM/ 45 l/s

Dimensions : L24" X W23" X H43". 78 lbs

ULTIMATE EXTREME CLEANING FILTER CARTRIDGE (PTFE) BY REVERSE PURGE (MRP)

Tiger-Vac's Manual Reverse Purge of the conductive filter cartridge (PTFE- surface area: 40 ft² [37 200cm²]) provides extreme and ultimate cleaning of the filter and maximizes the vacuum cleaners performance in a quick and effortless way. This is achieved by having the air suction intake reversed within the cartridge, thus purging it.

To operate, simply:

1. Close the gate valve at the suction intake, which will block the suction intake and create a maximum pressure inside the filter chamber.
2. Open the purging valve to allow air to flow inside the filter and blast off even hydroscopic particles of dust. Dust will fall at the bottom of the recovery tank for quick and easy disposal.
3. To achieve 100% performance of your vacuum cleaner, repeat two or three times as needed.

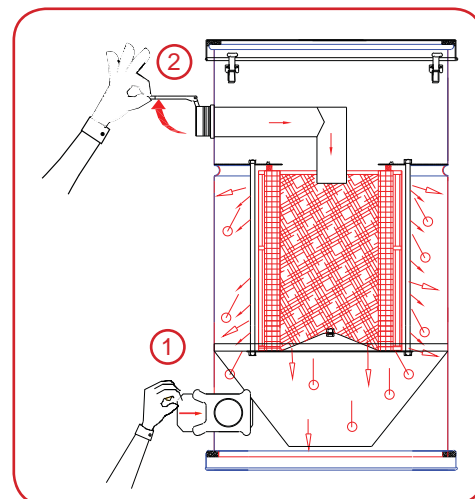

Included tools and accessories Ø1 1/2" (38 mm)



1	381400A	Kanaflex suction hose, SD*, Ø1.5" x 10' for 1.5" camlock inlet.
2	381364A	Wand Assembly with aluminum attachment, 2 pcs, stainless steel
3	381236	Universal Tool Assembly, SD*, 18", aluminum with conductive brushes & rubber blades.
4	381372D	Crevice Tool, 11", stainless steel
5	381185DA	Dusting Brush, with conductive brush, Ø5", aluminum with stainless steel adaptor.
6	383462D	Conical Nozzle with curved tip, 10", conductive rubber with stainless steel adaptor.

*SD: Static Dissipative and Conductive

When two or more commercial alloys are present and recovered by the vacuum cleaner, we recommend the vacuum cleaner be used in conjunction with a Liquid Immersion Separator.

10 OHMS :

In order to legally certify an Explosion Proof/Dust Ignition Proof vacuum cleaner system the unit must be static dissipative (SD*) and conductive and have a resistivity measuring less than 10 Ohms from the grounded air supply hose to any point on the vacuum cleaner system. This makes the unit eligible to be Explosion Proof/Dust Ignition Proof and be part of the Tiger-Vac's quality control management system ISO 9001:2000.

When using a pneumatic Explosion Proof Vacuum cleaner system the customer must make sure that the source of air supply (compressor) is grounded.

WARNING!

Only tools and accessories provided by Tiger-Vac shall be used with this vacuum cleaner. Any other tools used will render the warranty null and void any may cause an explosion which could result in bodily harm. Tiger-Vac will not assume any responsibility for damage that may occur due to the improper use or handling of the vacuum cleaner system.

For complete details please visit our website: WWW.TIGER-VAC.COM or contact one of our technical representatives.
Specifications are subject to change without notice. Images are for illustration purposes only. Tiger-Vac is a registered trademark.